



“WASHING & DISINFECTOR TUNNELS”

Trolley, Container, Bed & Cage
Hospital & Laboratory Application



Infection Control System



Infection Control System



“THE CISA GROUP COMPANY”

COMPANY PROFILE

CISA has been manufacturing and selling sterilization systems for over 60 years for both hospitals and industrial applications for all sterilization needs.

CISA is an Industrial Group which manufactures hospital and industrial machinery having integrated technological production systems with factories in different continents and its headquarters in Lucca, Italy.

Distributor coordination and technical service centres are managed through CISA branches, located in Joinville (Brazil) for Brazil and Latin America, in Amman (Jordan) for Middle East area, and Singapore for Asia,

as well as distributors and sales offices worldwide to ensure a constant presence and complete service in all countries in which CISA operates.

CISA takes part in a very important field, **sterilization**, that is in continuous development. For this reason it has focused its activity on a line of products that includes: infection control solutions, machinery for washing and disinfecting, machinery for high and low temperature sterilization, software systems for management control and medical waste treatments. All the products in the different lines are “made in CISA” from design to manufacture.

Gabriele Pacini
CEO

Cisa - Infection Control System

“WITHIN THE CSSD”

WHERE YOU CAN FIND ME

The Sterile Processing Department (Central Supply, or Sterile Supply as it is also known), comprises that service within the hospital in which medical/surgical supplies and equipment, both sterile and non-sterile, are cleaned, prepared, processed, stored, and issued for patient care.

The Washing Disinfector Tunnels CISA for Trolley, Container, and Bed (as shown on the legend) according the regulations of the CSSD is installed in the dirty area as washing apart department of large items.



*Cage washers CISA are only present and used for Laboratory application.

“Washing & Disinfector Tunnels”

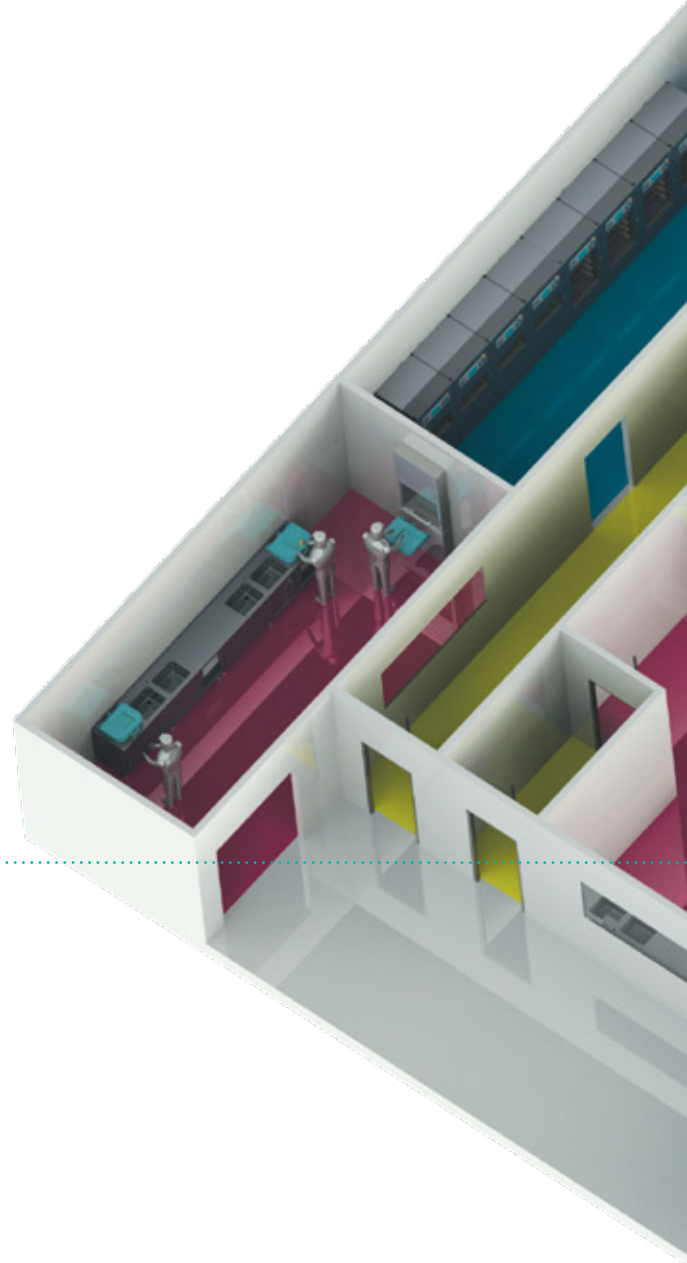
Trolley, Container, Bed & Cage
Hospital & Laboratory Application



Legend:

-  DIRTY AREA
-  CLEAN AREA
-  STERILE AREA

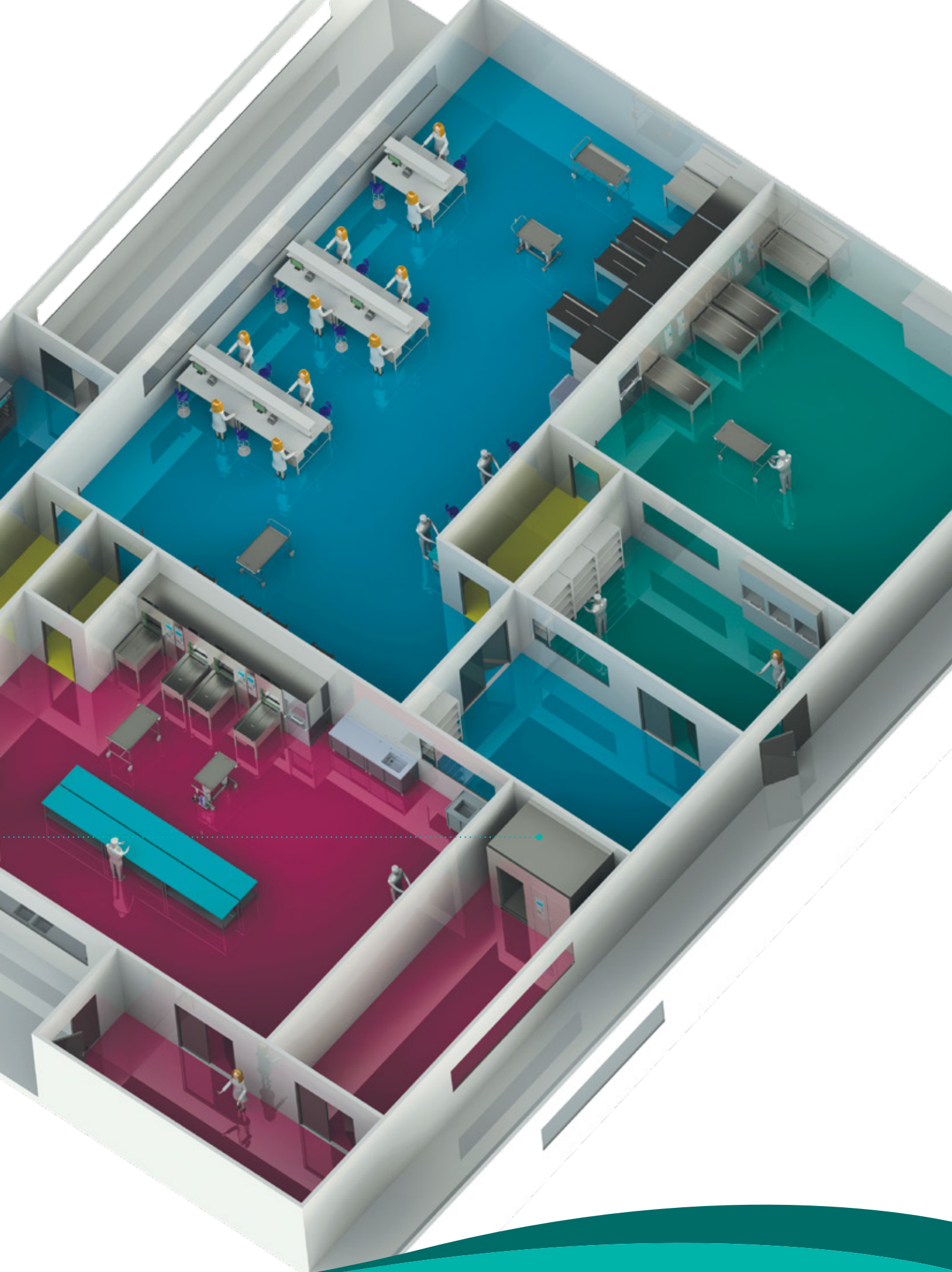

“DESIGN & INSTALLATION”

THE POWER OF CUSTOMIZATION



CISA washers for trolley Container, Bed and Cage are customizable in terms of function and design.

- The machine is available with double doors.
- The double door version is appropriate for modern CSSD (or Laboratory) pass through operations between dirty and clean zones.
- The machines are manufactured to European regulations including EN15883-1/-2 and relevant international standards.
- The machines are equipped with a PLC computerised control system and high quality components to guarantee the best performance and reliability.
- The structure of the machine is made from the highest quality materials for optimum hygiene, high durability and easy cleaning.
- The machines are designed with a user-friendly interface for the operators and in full compliance with environmental needs and a quiet operating environment.
- Installation and maintenance is possible by means of smooth and clear procedures.
- Compact architecture, with overall dimensions in small size compared to the machine capacity.
- Only 120mm deep pit hole
- One of the smallest in the market

The machine is designed with PLC industrial grade microprocessor control for higher safety and guaranteed reliability; CISA R&D engineers have used advanced design to optimize the machine for the use in hospitals, laboratories and research centers by working on quality, safety and ergonomoy.

The machine is built with highest quality components for perfect hygiene, perfect operation, high durability and maximum safety. They are designed with a simple user system for operators and in full compliance with environmental requirements and low noise emissions. The Installation and the maintenance of the machines are easy and for the most of the models is possible to be done from the frontal side of the machine itself. Compact architecture and high reliability, are the core features of all our models.



WASHING DISINFECTOR TUNNELS

The equipment has been designed and built for washing, rinsing, thermal disinfection and drying of hospital carrier trolleys, containers, beds and laboratory version for washing animal cages.

WHY TO USE A WASHER DISINFECTOR CISA

It has a wide range of applications for its washer/disinfectors using thermochemical disinfection with an aim of reducing infection risks. It is used for many reasons, such as, to:

- Provide safety for patients and staff by controlling and preventing contact with contaminated devices
- Reprocess medical devices that require high level disinfection
- Reduce the number of micro-organisms present on devices
- Remove blood, saliva, and tissue
- Reduce the microbiological load
- Remove dirtiness
- Improve the safety of the staff working in the centres

“CONSTRUCTION”

STAINLESS STEEL

For the construction of the machine is used the highest quality of stainless steel. The internal chamber and jacket are manufactured in AISI 316L. The frame and front panels of the machines are manufactured using stainless steel 304L. The hydraulic plant and pipes are manufactured using stainless steel 316L.

The pressure vessel as well all steam pipes are insulated using insulation material with high efficiency that reduces heat loss and stabilizes the temperature inside the pressure vessel to improve the quality of the washing cycles.

“WASHING CHAMBER”

HIGHEST QUALITY

The equipment consists of a washing chamber made of AISI 316L stainless steel. A series of lamps installed on the equipment roof of the machine illuminate the internal part of the washing chamber.

The inclined surface of the chamber bottom ensures perfect drainage and is equipped with a collection tank with a grid. The load platform is parted into removable modules to facilitate the internal inspection. The internal surfaces of the chamber are mirror polished.



“MAINTENANCE”

EASY ACCESS

Even though the overall dimensions of the machines are huge and large inside, thanks to the perfect designed position of the components, the machine is easily serviced. Furthermore, it requires minimum space for installation as well as all components can be serviced from the front.





“DOOR CONSTRUCTION”

SLIDING AND SEALING

The washers are provided with doors made from heat-resistant tempered glass, framed in stainless steel which allows viewing of the washing process. The doors are automatic horizontal sliding (SO) controlled from a touch screen and operated by an electrical motor. The double door configuration is fitted with a safety lock so that both doors cannot open at the same time, as well as to prevent cross contamination. The doors are fitted with gaskets for perfect closure during the cycle.

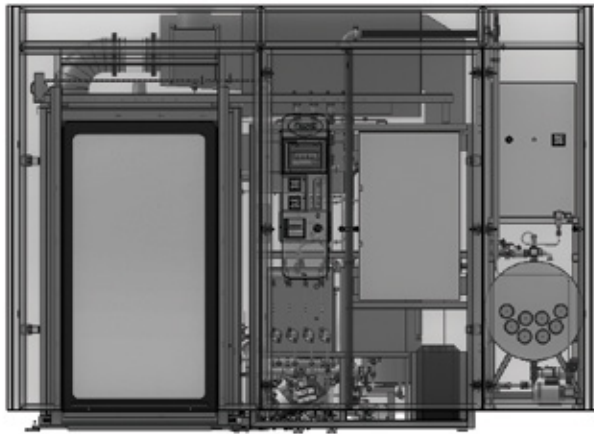

“TECHNICAL COMPARTMENT”

TWO WAY ACCESS

The washing equipment body and the components are contained in a technical compartment, adjacent to one side of the equipment. The compartment can be accessed through two doors flush with front and rear stainless steel panels.

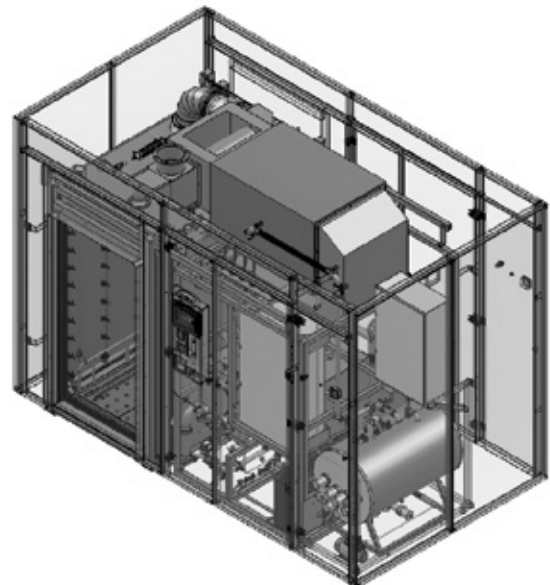
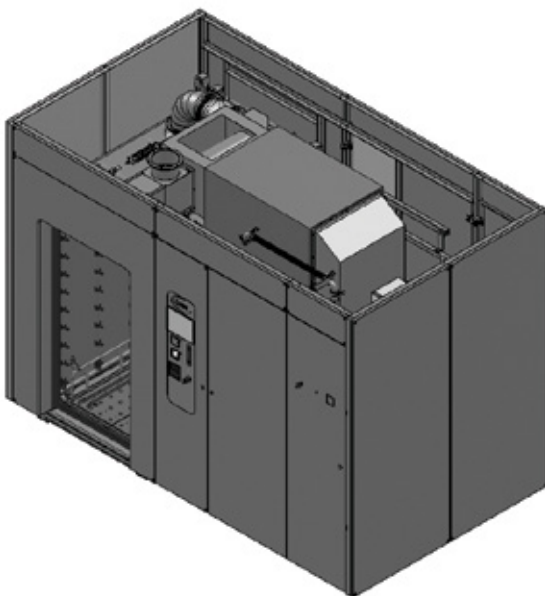

“ELECTRICAL PANEL” IN ONE CABINET

All the electrical components are connected to the terminal block and inside a cabinet with IP55 protection, except for the command and control components which are set up on the front panel.

“TANKS” DEMINERALIZED WATER

The two water collection tanks are both placed inside the technical compartment. The tank n.1, made from stainless steel, serves to load demineralized water for the final rinse inside the chamber to maintain the temperature, of n.4 steam resistors placed inside; the tank is also complete with level temperature control covered and insulated.

The second tank, n°2, also made of AISI 316L stainless steel, is bound to the load of hot and cold water for the pre-wash and washing inside the chamber and is complete with level control.



“CISA TROLLEY WASH WITH IMPELLERS” (ONLY WCO SYSTEM)

The second washing system is composed of one main connection from the top (two connection for double trolley washers WT/WCO3100) to the washing trolleys for containers/clogs/trays. This water connection line supplies the impellers installed under the washed materials. The wash arms as well are made with Tri-Clamp connections for easy removal.

“SIDE WASHING RAMPS” WASHING NOZZLES

The external washing of the components consists of two collectors to the right and the left of the platform supplying a series of vertical ramps equipped with washing nozzles.

During the cycle, the ramps are activated by a mechanism and rotate alternately orienting thoroughly the spray direction of the nozzles in order to cover completely the surface of the components to be washed. The machine is provided with a device to incline the washing platform in order to allow the water to drain during the drying phase, especially when using the closed trolleys.



“HYDRAULIC PIPING” IN STAINLESS STEEL

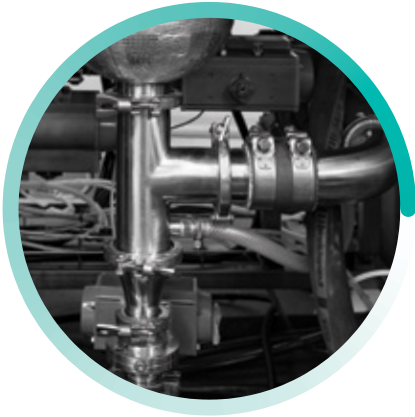

The hydraulic pipework and components are manufactured from sanitary AISI 316L stainless steel.

All supplies and the main drain are connected by flexible stainless steel tubing. The system can be easily removed and inspected thanks to its Tri-Clamp connections and stainless steel ball valves.

“RECIRCULATION” THERMAL DISINFECTION

The washing water in the outer tank is sent to the chamber, and then recirculated by the high flow pump and maintained at set temperature by the heat exchanger. During the washing phase in recirculation, chemical additives for the washing, neutralization and thermal disinfection chemical are added.

“DRYING SYSTEM” TOTAL REMOVAL

The final drying phase enables to fully dry water and vapour drops, and remove any material from the washing chamber. One unit equipped with a fan, G4 filter (95% efficiency) and heating batteries provide sterile hot air (91°C) to the chamber through several holes. The considerable air flow of the fan, reduces the drying time while the steam heating battery heats the air up to a set temperature. The air is taken from the technical compartment, filtered and then passes through the heating battery where it is finally channelled in the washing chamber. The exhaust air leaving the chamber which is, still hot, is channelled at the entrance of the drying group in order to pre-heat the incoming fresh air. One PT100 probe close to the heating battery checks the air temperature.

* For models WT/WC03100 the drying system described above is doubled for necessities of chamber capacity.

“DOSING PUMPS” THREE DOSING PUMPS

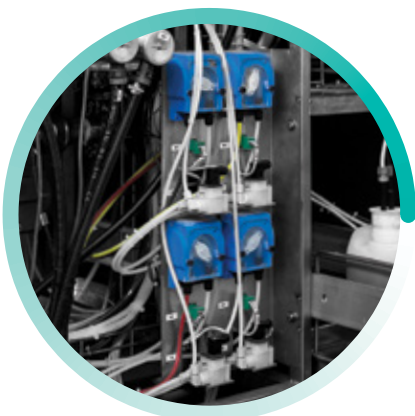

Chemical additives to increase the washing and disinfection effects of the materials, are added to the water by means of three dosing pumps, which collect the liquid directly from the tanks placed in the technical compartment. The considerably low flow rate of the dosing pumps and the dosing control, carried out by a meter connected to the microprocessor, allow the amount of additives added to water to be optimised and the relative consumptions to be reduced. A level control for each tank indicates the presence of additive until it is fully emptied. The additive is injected directly in the washing chamber, where it is mixed with water. The additives that can be added usually are: detergent, disinfectant, neutraliser and lubricant.

“WASHING PUMPS”

PRE-WASHING

A pump starts the circulation of the washing water by distribution in the two lines placed on the washing trolley and on the side ramps. The water is filtered by means of a self cleaning filter to the circulation pipe and heated by a steam in-line exchanger.

Another pump, at the end of the washing cycle, allows emptying the chamber and gives the possibility to the client to collect the final rinsing water into tank n°2, with a reason to use it in the pre-washing of the next batch, according to customer's needs.

*For models WT/WCO3100 the washing group described above is doubled for necessity of chamber capacity.

“SAFETY SYSTEMS”

TOTAL PREVENTION

The machine is equipped with the following safety devices that make it extremely reliable:

- Door blocking device when cycle is running.
- An anti-overheating device during the disinfection/washing phase.
- A temperature defect device during the disinfection/washing phase.
- A device that prevents the cycle starting if the door is open or not perfectly closed.
- Safety overflow device.
- Device that prevents the doors from opening simultaneously
- Circuit breakers to protect the motors.
- A fuse and electrical protection on the auxiliary devices of the electrical system.

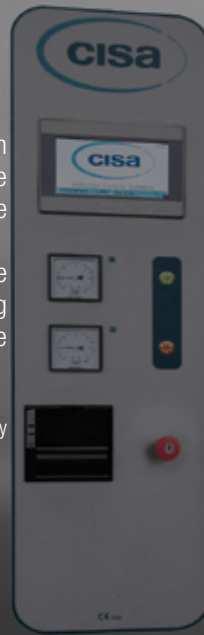

- Emergency button that stops all the machine functions (restored to stand-by using the key and the cycle functions are resumed via the start command).
- Emergency button that stops all the washing chamber functions.
- Differential protection on hot water electric circuit (resistances)
- Safety thermostat for generator resistances.
- Generator safety valve.

NO RISKS, DOUBLE PROTECTION

- Releasing micro-switches on electric panel
- Double buttons (requires two hands) to close the door
- Emergency Buttons on control panels to immediately stop the working of the equipment
- Safety device enabling to open the door from the inside

“QUALITY & SAFETY”

OUR CERTIFICATES

The autoclaves CISA P-LS comply with the Machinery Directive 2006/42 / EEC Directive and Directives 2004/108 / EC (EMC) and 2006/ 95 / EC (LVD) . They also meet the following electrical standards IEC EN 61010-1:2013 , IEC EN 61010-2 040:2005 , IEC EN 60204-1:2010 . The pressure vessels are in compliance with the Directive PED 2014/68/EU.



“ALARMS” AUDIO & VISUAL

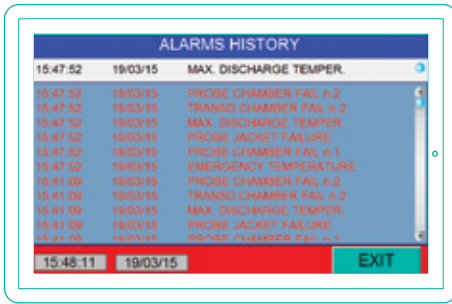

Audio and visual alarms are defined for operator warning. The alarms are included in a multi-level alarm list with clear message notification; alarm levels are configured based on the level of importance to stop the machine or the cycle as well as just warning notification without affecting the running cycle. The alarm lists are complete for safe and perfect operation for the operators and the machines. The alarms history can display all the alarms that occurred in last 90 days. The end cycle alert is included to alert the user for the finished cycle and to do the unloading process.



“MULTI LANGUAGE TOUCH SCREEN” WORLD LANGUAGES

Most world languages are pre-installed in the machine. Users can easily choose them from the touch screen, including: English, Italian, French, Spanish, Arabic, Russian, Portuguese, German, Turkish, Polish, Chinese, Greek, Romanian, Korean, Bulgarian and others.

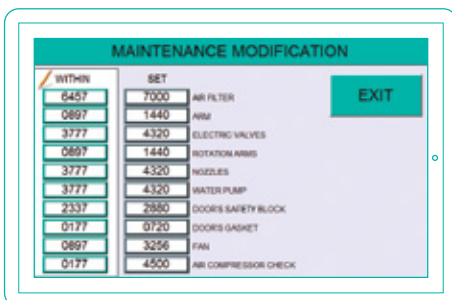

“SERVICE & MAINTENANCE PROGRAM” PREVENTIVE MAINTENANCE

The touch screen is equipped with software pages for periodic preventive maintenance, enabling a safe functioning of the machine, and auto maintenance program for steam generator discharge with user acceptance. There are technical pages for calibration and parameter control. Easy and friendly troubleshooting pages are added for easy maintenance and service. The maintenance and technical pages are protected with password where only authorized technicians have access.



“REMOTE MAINTENANCE” REMOTE ACCESS SYSTEM

The machine, through Touch Screen, is equipped with an remote access system that allows to be connected to CISA customer service by a simple ethernet connection. This represent the fastest way for a CISA technician to do a check up of the problem and reduce the down time.

“HEATING”

MANY METHODS

The washer/disinfector water can be heated using one of the following methods:

(E): Built-in electric heating, using a steam generator in a separate technical compartment

(V): External steam supply from Hospital steam Network (domestic Vapour)

(EV): Combination of (E) and (V) which enables the user to select the type of heating from the touch screen, choosing either internal (E) or external (V) without the need to interact with a hardware interface.

“CONTROL PANEL”

LOADING SIDE

The control panel consists of:

- A 7” colour touch-screen programmable terminal that controls interaction with the operator.
- Emergency button
- An on/off equipment selector
- A graphic alphanumeric printer
- Door opening/closing buttons
- Air pressure gauge
- Network steam pressure gauge

“CONTROL PANEL”

UNLOADING SIDE

The unloading side control panel consists of:

- Door opening/closing buttons
- Emergency button
- Control light showing cycle phase and alarms
- An on/off equipment selector
- Air pressure gauge
- Network steam pressure gauge



LOADING SIDE



UNLOADING SIDE

“TOUCH-SCREEN”

The control display with an actual display size of 7” a colour touch screen.



Main menu
Cycle menu
Cycle parameters
Data regarding the load (operator, batch)
General system conditions for the start of the cycle
Diagram of the process variables in real time
Process control
Scheduled maintenance
Alarms
Alarms history
Temperatures
Various messages (door status, temperature, etc.).

The system can perform a self-diagnosis and check the thermodisinfectors for the following alarms:

Minimum/maximum disinfection temperature alarm
No supply voltage alarm
No hot/treated water supply alarm
Overload relay alarm
Minimum tank level alarm
Temperature probe fault alarm
Maximum phase time alarm



“THERMAL PRINTER”

The printer is printing the parameters and regular execution of the cycles. The data showed in the printout are the basic process parameters and each alteration of stage, further date, time, the result of cycle, operator code, lot, A0 etc are also reported. Besides, on the self-certification are reported the number of cycle in progressive order.

“WASHING CYCLES”

PROGRAMMED SEQUENCE

These are obtained via the system that controls the trolley/container washer.

The sequence of the various phases of the cycle is subject to the intended conditions and set parameters being reached.

The programmed cycles are as follows:

1	P1 Trolleys 60° 3' Washing/chemical disinfection cycle of trolleys at 60°C for 3'
2	P2 Trolleys 91° 1' Washing at 60°C for 5' and thermal disinfection of trolleys at 91°C for 1'
3	P5 Container 60° 6' Washing disinfection of containers at 60°C for 6'
4	P6 Container 91° 1' Washing at 60°C for 10' and thermal disinfection of containers at 91°C for 1'
5	P9 Clogs 91° 1' Washing at 70°C for 10' and thermal disinfection of clogs at 91°C for 1'
6	P13 Drying cycle.

“OPTIONALS”

SOMETHING FOR EVERYONE

MIRROR REVERSE MACHINE

Depending on installation needs and to facilitate the operations of ordinary and extraordinary maintenance, the equipment can be configured with standard or inverted module.

In the first case the chamber is placed on the left (looking from the loading side) and the technical module to the right, and in the second case the chamber is placed on the right side and the technical module is placed on the left. This optional varies from the request of the client.

FLOOR LEVEL ADJUSTMENT FOR CONCEALED INSTALLATIONS

Depending on the customer's requirements, the machine can be installed at floor level and loaded without aid of external trolleys.



SIDE PANELS

The machine can be equipped with side closure panels on one or both sides to meet with installation requirements.



DOUBLE TOUCH-SCREEN

An additional touch-screen can be installed on unloading side of a double door equipment upon request. This type of requirement may arise in some situations, such as hospital or a laboratory where the loading side is the laboratory itself and the unloading side exposes on a decontaminated area.

Equipment control settings can be also customised and the operator can set one of the two sides control as main one, still in accordance with standard requirements.



UPS BACKUP CONTROL SYSTEM

The backup UPS system is connected to the PLC and the touch screen and does not allow the cycle to be lost in case of sudden changes in voltage or power cuts, as long as the cycle conditions are still valid.



“CAGE WASHER” EASY USE

CISA CAGE Washing Tunnel is a system that with a thermal and chemical washing, washes and disinfect all types of animal cages preventing contamination in the field of animal care.

The CAGE Washing Tunnel is designed in a special way that all research laboratories and animal care facilities can use it with ease. It has been designed a special trolley which inserted in the washer allows external washing and drying of the cages which are already inserted inside, separating and dividing the plastic compartment from the metal grid of the cage.

* CISA has an option to customize the trolley according the clients request and needs.

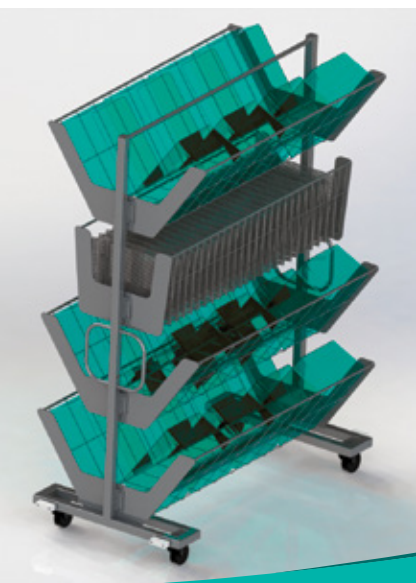

“MODELS”

OUR PRODUCT RANGE

All of the sizes and measurements below can be changed according to the different configurations and applications of the machines.

	CHAMBER DIM	DIMENSIONS 1P-2P	LT	LOAD CAPACITY	
P-WT 1500	900x1700x1550	2750x2400x1950	2370	N.1 TROLLEY MAX DIM 850x1500x1400 N.1 TROLLEY 16 ISO CONTAINER N.1 TROLLEY FOR CAGE DIM 850x1500x1400	
	900x1700x3100	2750x2400x3500	4740	N.2 TROLLEY MAX DIM 850x1500x1400 N.2 TROLLEY 16 ISO CONTAINER (TOT. 32) N.2 TROLLEY FOR CAGE DIM 850x1500x1400	P-WT 3100
P-WCO 1500	900x2000x1550	2750x2700x1950	2790	N.1 TROLLEY MAX DIM 850x1800x1400 N.1 TROLLEY 20 ISO CONTAINER N.1 TROLLEY FOR CAGE DIM 850x1800x1400	
	900x2000x3100	2750x2700x3500	5580	N.2 TROLLEY MAX DIM 850x1500x1800 N.2 TROLLEY 16 ISO CONTAINER (TOT. 40) N.2 TROLLEY FOR CAGE DIM 850x1500x1800	P-WCO 3100
P-WB 2500	1050x2000x2500	2900x2700x2900	5250	N.1 BED MAX DIM 1000x1800x2350 N.1 TABLE MAX DIM 1000x1800x2350 N.2 TROLLEY MAX DIM 850x1800x1100 N.1 TROLLEY 20 ISO CONTAINER N.1 TROLLEY FOR CAGE DIM 1000x1800x2300 N.2 TROLLEY FOR CAGE DIM 1000x1800x1100	





Infection Control System

**Cisa Production
Headquarters**

Via Enrico Mattei snc
55100 Lucca, Italy
P. +39 0583 1538105
F. +39 0583 1538127
d.vendite@cisagroup.it
export@cisagroup.it
www.cisagroup.it

Cisa Asia Office

190 Middle Road
#19-05 Fortune Centre
188979 Singapore
P. +65 6826 1065
M. +65 919 09122
asia.sales@cisagroup.net

Cisa Brasile Ltda.

Rua Dona Francisca, 8300 Distrito
Industrial Bloco I, Módulo 2
CEP 89239, 270 Joinville
SC Brasil
P. +55 47 3801 9090
cisa@cisabrasile.br

Cisa Middle East Ltd.

P.o Box, 3692
11821 Amman, Jordan
P. +962 6 556 3091
P. +962 6 556 3092
F. +962 6 556 3093
middleeast.sales@cisagroup.net