

Dimension[®] RxL Max[®] clinical chemistry system
with **Sample Transfer Module (STM)** and
Reagent Management System (RMS)
Instrument Specifications

Effective: December 2008

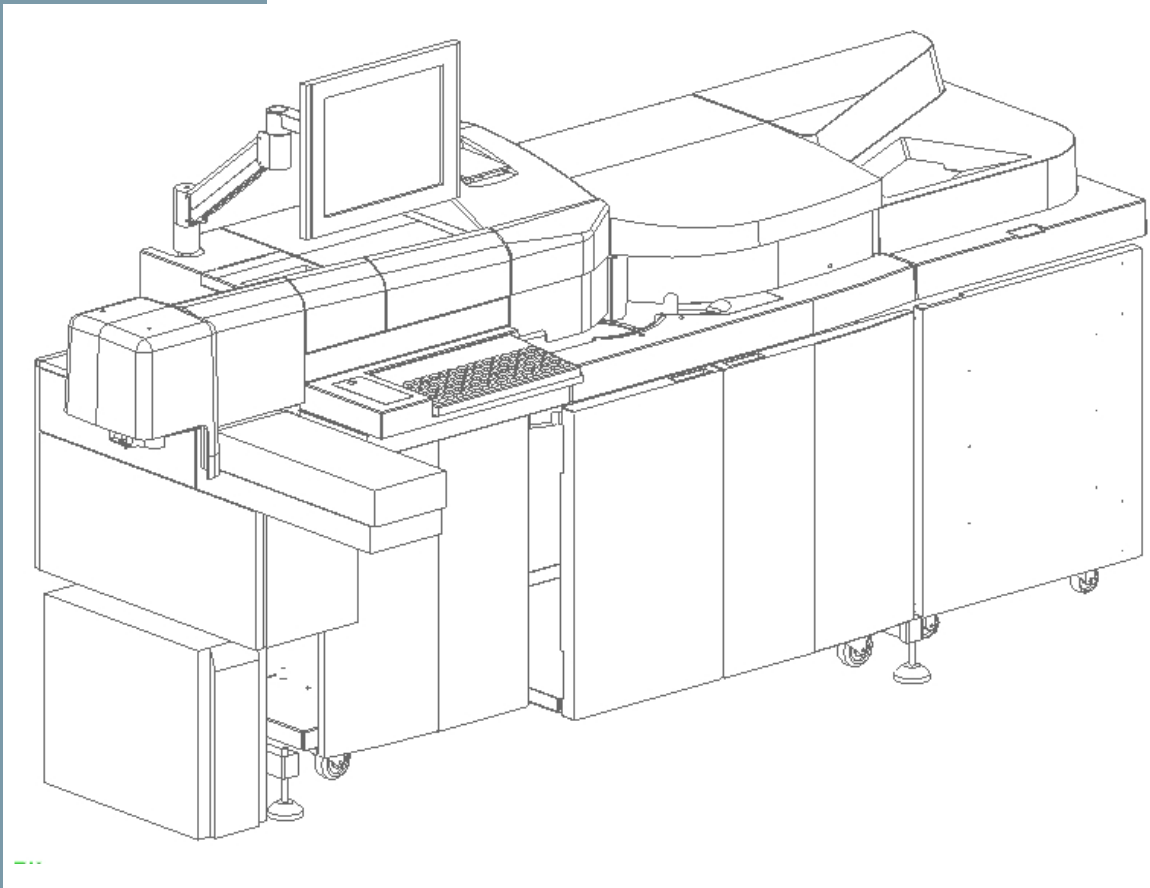

Instrument Weight and Dimensions

Weight

RxL Max[®] (HM, STM, RMS) –
1250 lbs. (567 kg)

Dimensions

RxL Max[®] (HM, STM, RMS) –
110 in. (280 cm)¹ wide x 68 in. (170 cm)¹
high with monitor x 32 in. (88 cm) deep

Additional Minimum Instrument Clearances*

- Raised lids: 67 in. (170 cm). RMS lid is mechanically interlocked with instrument reagent area lid so that both must be opened to access the RMS.
- Monitor overhead clearance – 19 in. (48 cm)
- Right Side, System – 30 in. (76 cm)
- Ventilation clearance in back – 30 in. (76 cm) for adequate instrument ventilation.
- Doorway opening for installation – 32 in. (81 cm)

*Clearances are estimates since the Dimension[®] System is raised to the level of the StreamLAB[®] workcell.

Notes:

UPS must be installed in same room as instrument. UPS should be installed on left side of instrument (when viewed from front); if installed in back, allow 11 in. (28cm) of clearance.

The instrument keyboard can be raised to reduce the depth from 32 in. (81 cm) to 30.5 in. (77 cm) for moving the instrument through doorways.

The RMS and instrument are normally shipped and moved separately. They are joined together at their permanent location.

1. Required for raising instrument lids.

Room Environment

Operating Temperature (Combined RxL Max[®], STM, RMS System)

Room temperature must be 65–85°F (18–29°C) with a maximum fluctuation of 5°F (2.8°C) per hour. The system requires two hours to warm up from a cold start to the operating temperature.

Relative Humidity (Combined RxL Max[®], STM, RMS System)

Operating humidity: 20 to 80% non-condensing

Maximum Thermal Output

RxL Max[®], STM, RMS (all voltages) –
6318 Btu/hr (1.9 kwh)

Average Noise Output (Combined RxL Max[®], STM, RMS System)

<75 dBA at 1 m while operating

Water Requirements

Water Consumption @ maximum throughput

- 1.32 gal./hr (5.0 L/hr)

The water required by the RMS module is supplied by the Dimension[®] RxL Max[®] instrument on-board water bottle. RMS water specification is the same as for the instrument.

- Instrument feed water: must maintain stable dO₂ content between 5 and 8 ppm
- Temperature: < 35°C
- Resistivity: ≥ 10 megohms cm
- Bacterial content: ≤ 10 colony-forming units/mL
- System feed water line must not exceed 12 feet
- System is supplied with water system

Waste Requirements

Liquid Waste Output (combined RMS and RxL Max[®] system)

1.1–1.32 gal. /hr (4.5–5.0 L/hr)
@ maximum throughput

Liquid wastes are aspirated from all instrument and RMS sources to the RxL Max[®] waste bottle. The waste is considered biohazardous, consisting of condensate and probe wash water, reagents and NaOH probe cleaner. The disposal point should be selected in accordance with local hazardous waste guidelines.

Maintenance of the waste tubing from the instrument to the disposal point is the responsibility of the user.

Electrical Installation Requirements

Current/Operating Power Requirements

	Nominal Line Voltage VAC	Line Voltage Voltage VAC	Nominal Line Frequency HZ	Maximum Continuous Current, AMPS	Power Consumption (WATTS)
RxL Max® (with STM and RMS)	115	103 to 127	47 to 63	17	1955
	230	207 to 253	47 to 63	11	2530

Wiring Options (RMS and Instrument System)

One of two line wiring options may be chosen to connect the RMS and instrument to line power. These options apply to the U.S.A. relative to wire sizing, and apply worldwide relative to circuit isolation requirements.

Option 1

If the Dimension® instrument is plugged into a dedicated 20 amp single receptacle, which is connected to service with 10-gauge wiring, another single receptacle may be parallel wired from the instrument receptacle for the RMS. If this option is used, the service circuit breaker must be 20 amps. This option also ensures that both the Dimension® RxL Max® instrument and the RMS Module receive from the same power source.

Option 2

The RMS and the instrument each have their own dedicated line wiring and wall line receptacle. The line wiring for the instrument is specified on the instrument specifications sheet. RMS wiring requirements are as follows:

RMS

Line wiring to be separate, dedicated line with Hot (phase), Neutral, and isolated ground wires in a conduit. Conduit should start at the service distribution panel and be continuous to the instrument receptacle. The conduit should contain no other active circuits. The ground wire should start at the distribution panel ground bus and be continuous to the receptacle in accordance with NEC paragraph 250-74, unless local or international codes prohibit.

Either 14 or 12 AWG wiring may be used to connect the RMS to the service distribution panel.

WARNING! If Option 2 is chosen, the two separate branch circuits must originate from the same power phase in the distribution panel.

Receptacle

Customer must provide a Hospital Grade receptacle, installed by a qualified electrician before arrival of the instrument. The receptacle must be accessible to the 9-ft. (2.7 m) power cord furnished with the instrument.

The USA requires NEMA #5-20R 20 amp straight blade receptacle (Hubbell receptacle No. IG-8310 or equivalent.)

Installation

The Dimension® RxL Max® with STM and RMS will be installed by a qualified Siemens Healthcare Diagnostics Inc. representative. The installation will include checkout of all aspects necessary to ensure the equipment is fully operational.

Phone Line Requirement

- Dedicated, direct line connected to the Dimension® RxL Max® system (not through a switchboard)
- Full duplex, capable of two-way transmission
- Standard phone connection (not digital)
- RJ11C or RJ11W phone jack

Host Interfacing

A 25-pin female connector is required for hookup to the male connector used for host communications port.

Leakage Current

	115 V ac/60 Hz	230 V ac/50 Hz
Normal Supply Connections	Under 78 µA	Under 58 µA
Ground Disconnected	Under 180 µA	Under 117 µA
Measurement Standard	UL 3101-1	EN 61010-1

Leakage current complies with the requirement of UL 3101-1, CSA22.2 No. 1010-1 and TUVS Certification for EN6010-1 safety standards for non-patient-vicinity laboratory equipment.

Code Compliance

Safety Compliance

The Dimension® RMS module has been designed and tested to comply with safety standards UL3101-1, CSA C22.2#1010.1 and EN61010-1 under the following environmental conditions [subclause 1.4]:

Temperature	5°C (41°F) to 40°C (104°F)
Humidity	Maximum 80% at 31°C to 50% at 40°C
Altitude	Maximum 2,000 m (6,562 ft)
Main Supply	115±10% vac or 230±10% vac, 50/60Hz
Overvoltage Category	Category II, connected to a branch circuit
Pollution degree	Degree 2, normal indoor laboratory environment. Air contains only non-conductive pollutants with occasional condensation.

Additional *functional* environmental conditions are discussed earlier in this document.

Emission Compliance

The Dimension® RxL Max® with STM and RMS has been designed and tested to CISPR 22 Class A. In a domestic environment it may cause radio interference, in which case you may need to take measures to mitigate the interference.

The Dimension® RxL Max® with STM and RMS should not be used next to any Industrial Scientific and Medical (ISM) equipment that must functionally produce RF energy (e.g., diathermy equipment).

Barcode Scanner

The barcode scanner uses Class I LEDs (light-emitting diodes) and is not hazardous to your eyes.